

## UNI-C-Controller 2.2 Mainboard IO

C. Meyer 10/2006, 03/2010

### 4-fach D/A-Wandler mit umschaltbarer Polarität

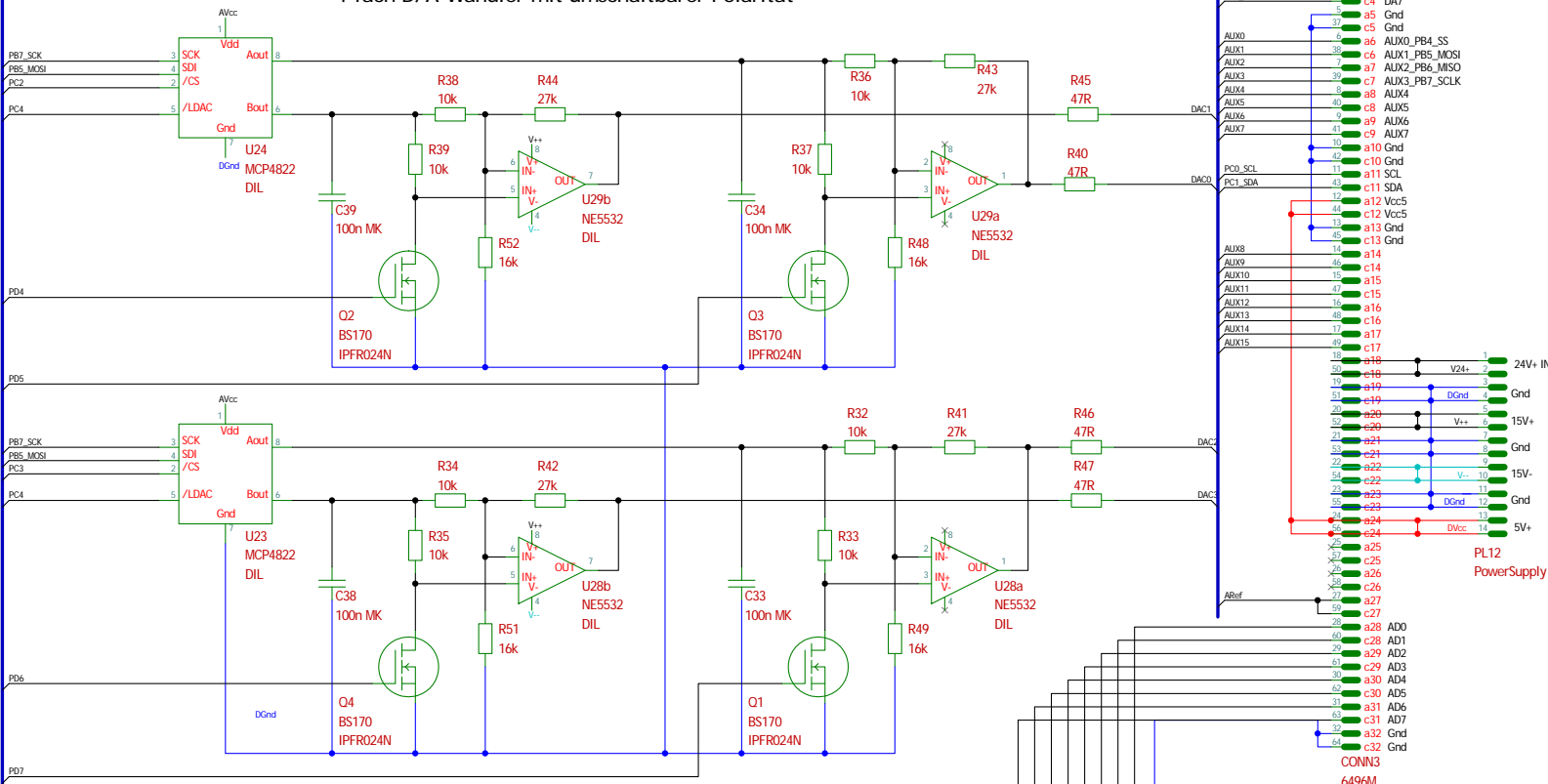

### 8-fach A/D-Wandler 12 Bit

